

30

/ /
/
/
LED

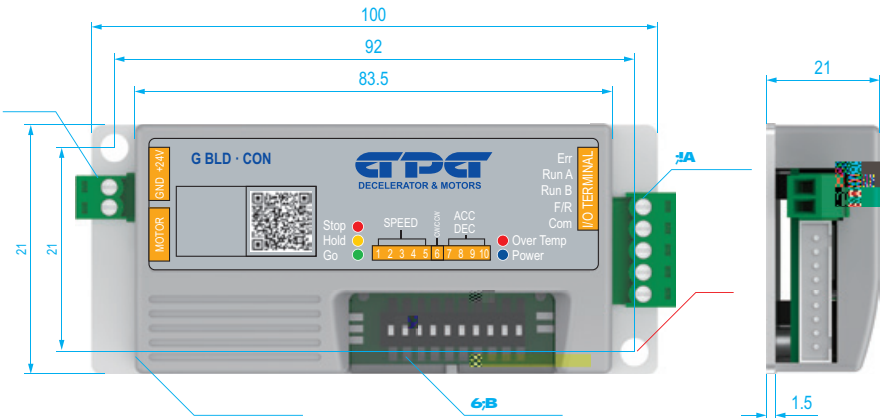

	Op50°C
	<80% RH
	1000M
	5.7m/s
	- 20p50°C





		24V \pm 5%	
		2.8A	3A
	ERROR	+24V	
	RUN A		
	RUN B		
	REVERSE		
	COMMON	0V	

DIP

		OFF	ON	
1p5				
6				
7p10	/			

<p>NPN</p> <p>DC24V GND</p> <p>PNP</p> <p>DC24V GND</p>	RUN A	RUN B	
	ON	OFF	100%
	ON	ON	75%
	OFF	ON	50%
OFF	OFF		

/ DIP SW7-10)

SW7	SW8	SW9	SW10	/
OFF	OFF	OFF	OFF	0.05
OFF	OFF	OFF	ON	0.10
OFF	OFF	ON	OFF	0.20
OFF	OFF	ON	ON	0.30
OFF	ON	OFF	OFF	0.40
OFF	ON	OFF	ON	0.50
OFF	ON	ON	OFF	0.60
OFF	ON	ON	ON	0.70
ON	OFF	OFF	OFF	0.80
ON	OFF	OFF	ON	1.00
ON	OFF	ON	OFF	1.20
ON	OFF	ON	ON	1.40
ON	ON	OFF	OFF	1.60
ON	ON	OFF	ON	1.80
ON	ON	ON	OFF	2.00
ON	ON	ON	ON	2.50

LED

	STOP	HOLD	GO	OVER TEMP	POWER
			10		
	6				
<12V	5				
>32V	2				
				8	

GBLD 6010

15A

50V

30

/ /
/ /
/ /

0- 10V



	Op50°C
	<80% RH
	1000M
	5.7m/s
	- 20p50°C



G BLD 6010- P

»
»
»

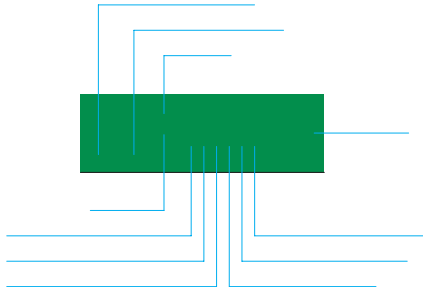

		24p50V	
		10A 15A 3s	
	PLS		
	ERR		
	VREXT	Op10V	
	DIR		
	RUN		
	RUN A		

PLC

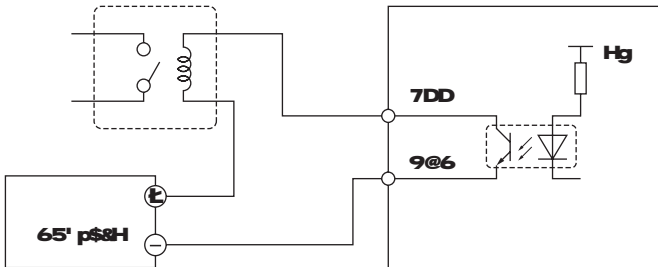
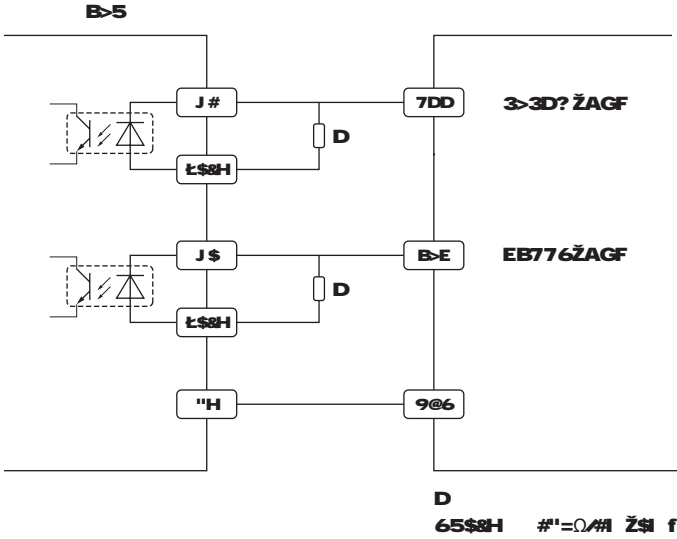

GBLD6010

1		
2		
3	MOS	
4		
5		
6		
7		
8		

台邦电机工业集团有限公司

7

1688.7 77 7 77

1688.7 77 7