

BLDG50 电动滚筒 BLDG50 Drum Motor

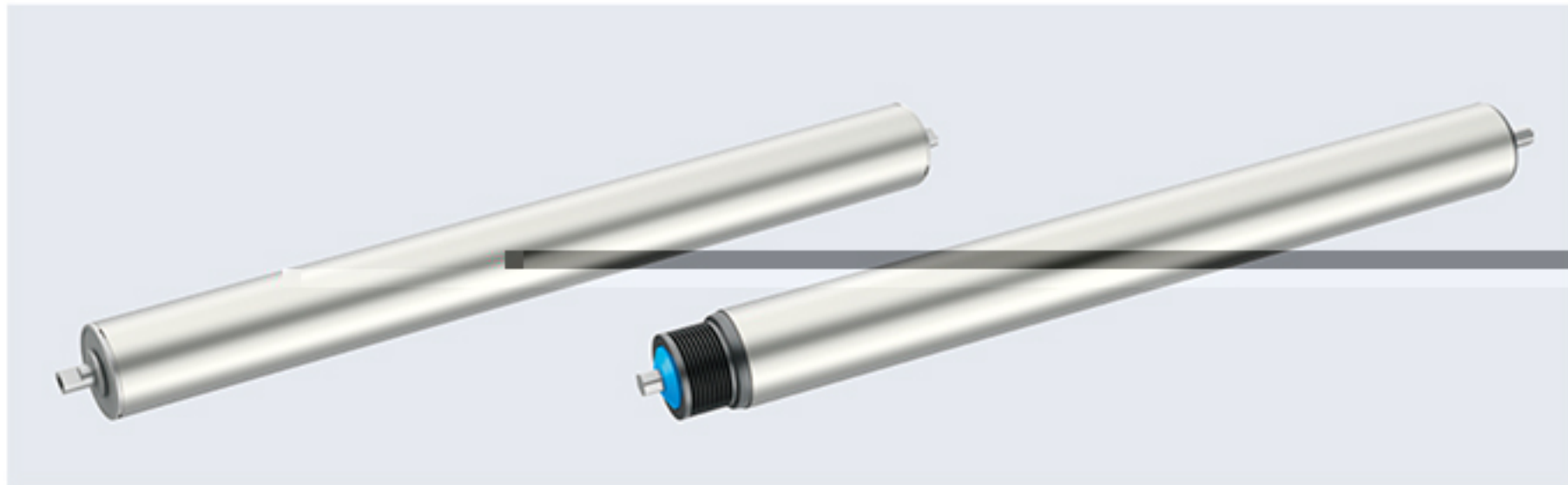

■ 产品概述 Product Description

此款电动滚筒式空间极其有限的情况下，仍可以安装得到要求的力矩。采用高合金钢精磨齿轮和行星传动结构为主体设计，具有性能可靠、免维护、免加油、适合较小的安装空间等诸多优点。适用于多个领域：

This type of drum motor can be installed in limited space and meet the torque requirement. Using alloy steel grinded gears and planetary transmission structure, it is reliable, free of maintenance and oil-renewing, space-saving. It can be use in many fields:

- 超市收银台 Supermarket cashier
- 包装机械 Packaging machinery
- 皮带输送线 Belt conveyor line

■ BLDG50 电动滚筒特征 BLDG50 Characteristics Of Drum Motor

● 筒体 Drum Shell

• 标准筒体为低碳钢材质 • 食品级筒体为 304 不锈钢 • 标准筒体表面加工有防滑滚花 • 齿轮传动 • 高合金钢精磨齿轮，确保传动时低噪音 • 行星齿轮传动

• Material of standard drum shell is mild steel • Food grade shell is 304 stainless steel • Standard cylinder rolling mill gear slip flower-gear • Gear drive • High alloy steel gear precision, ensures low noise transmission • Planetary gear transmission

■ 电机基本特性 Basic Characteristics Of Motor

● 外径 50 滚筒 (DC 电源时适用于 24VDC/48VDC) External diameter 50 drum motor (DC Power Supply When Applied To 24VDC/48VDC)

项目 Item	单位 Units	参数 Parameters	参数 Parameters	
额定功率 (连续) Rated power (continuous)	W	40	60	
额定转速 Rated speed	r/min	3500	3500	
额定转矩 Rated torque	N.m	0.11	0.16	
瞬时最大转矩 Instantaneous maximum torque	N.m	0.44	0.64	
速度控制范围 Speed control range	RPM	200~3500	200~3500	
速率变化率 Speed control range	对负载 On load	± 1.0% 以下：条件 0~ 额定转矩、额定转速、额定电压、常温 Below ± 1%: condition 0~ rated torque, rated speed, rated voltage, room temperature		
	对电压 On voltage	± 1.0% 以下：条件额定电压 ± 10%、额定转速、额定负载、常温 Below ± 1%: condition rated voltage ± 10%, rated speed, rated load, room temperature		
	对温度 On temperature	± 1.0% 以下：条件使用环境温度 0~+40°C 额定转速、额定负载、额定电压 Below ± 1%: conditions of ambient temperature 0~+40°C rated voltage, rated load and rated speed		
电源输入 Power input	额定电压 Rated voltage	V	24VDC	24VDC
	电压容许范围 Voltage tolerance range		10%	10%
	额定输入电流 Rated input current	A	2.40	3.60
	瞬时最大输入电流 Instantaneous maximum input current	A	9.60	14.4

■ BLDG50 皮带输送滚筒尺寸图 BLDG50 Belt Conveying Drum Motor Outline Dimensions

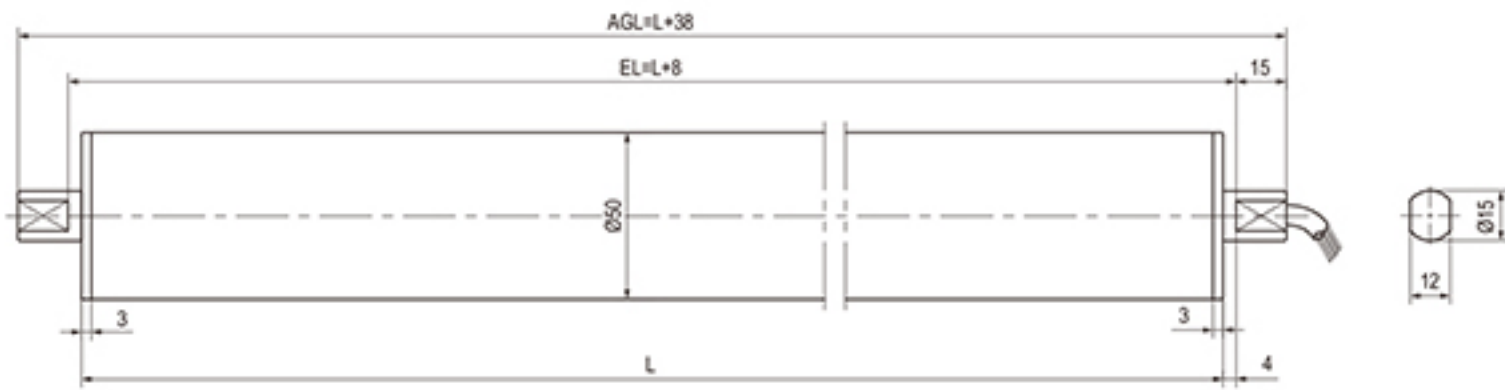

■ BLDG50 料箱输送滚筒尺寸图 BLDG50 Material Box Conveying Drum Motor Outline Dimensions

多楔带 PJ 型 (9 槽)

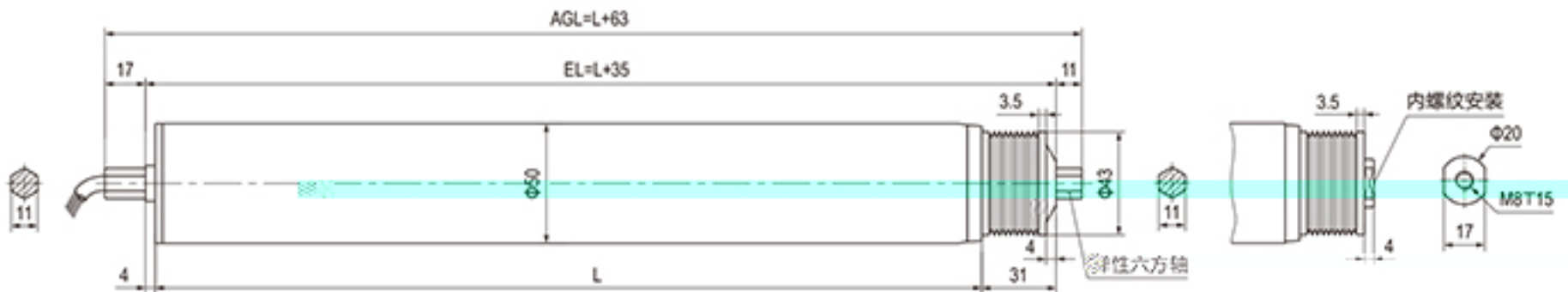

双链 (08B 14T)

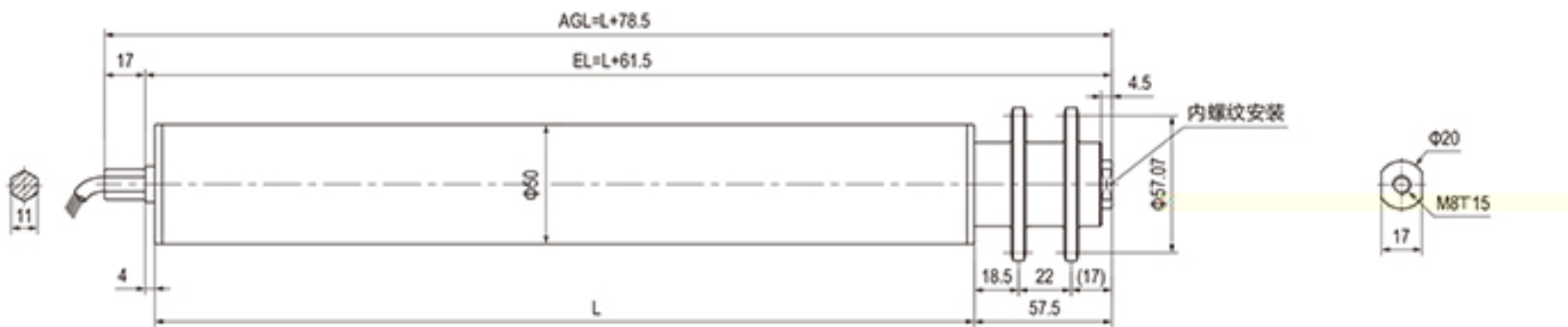

O 型槽 双槽型 (R5)

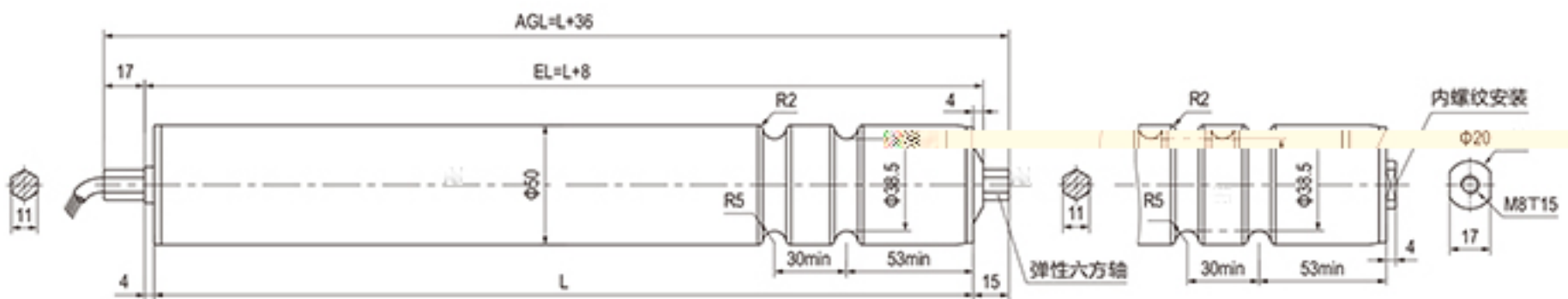

■ BLDG50 机械参数 BLDG50 Mechanical Parameters

额定功率 P Rated Power P W	齿轮箱级数 Gear Box Series	减速比 i Reduction Ratio i	额定转速 n Rated Speed n RPM	额定线速度 V Rated Speed V m/s	额定扭矩 T Rated Torque T N.m	牵引力 F Traction F N	最小筒长 L Min Tube Length L mm
40	1	3	1167.00	183	0.3	12	270
		4	875.00	137	0.41	16	270
		5	700.00	110	0.51	20	270
		8	438.00	69	0.81	32	270
	2	12	292.00	46	1.13	45	280
		16	219.00	34	1.5	60	280
		20	175.00	27	1.88	75	280
		25	140.00	22	2.35	94	280
		32	109.00	17	3	120	280
		40	88.00	14	3.75	150	280
	3	60	58.00	9	5.63	225	300
		80	44.00	7	6.99	280	300
100		35.00	5	8.73	349	300	
60	1	3	1167.00	183	0.46	18	270
		4	875.00	137	0.41	16	270
		5	700.00	110	0.76	30	270
		8	438.00	69	1.22	49	270
	2	12	292.00	46	1.69	68	280
		15	233.00	37	2.11	84	280
		20	175.00	27	2.82	113	280
		25	140.00	22	3.52	141	280
		32	109.00	17	4.51	180	280
		40	88.00	14	5.63	225	280
3	60	58.00	9	7.86	314	300	

• 我们也提供其他线速度 V 要求和更短筒长 L 的特殊定制滚筒，请联系我们获取详细信息。

BLDG50安装支架 BLDG50 Mounting Bracket

标准型安装支架 (电缆端)

Standard mounting bracket (cable end)

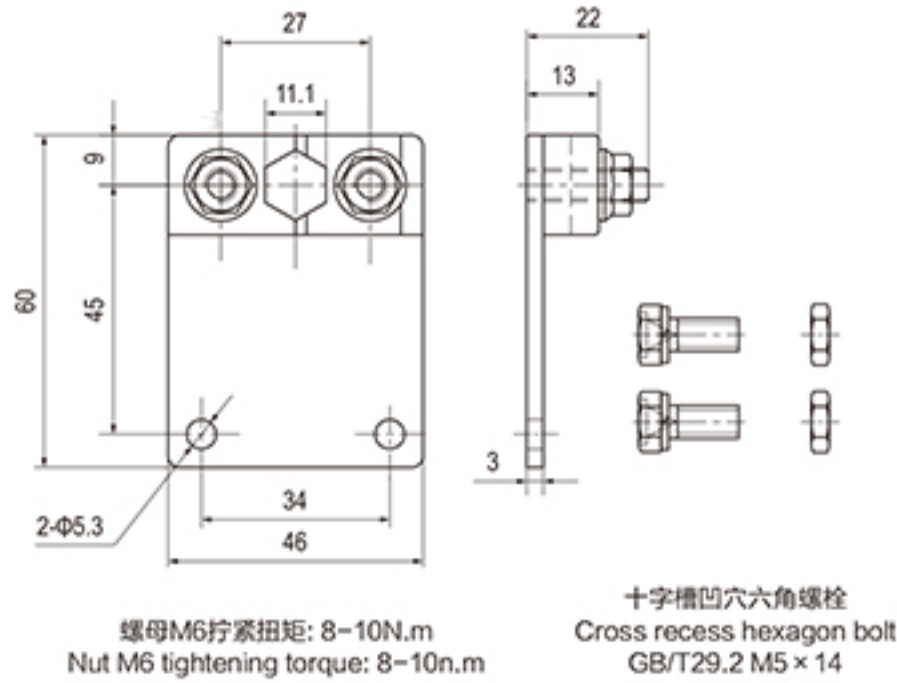

紧凑型安装支架 (电缆端)

Compact mounting bracket (cable end)

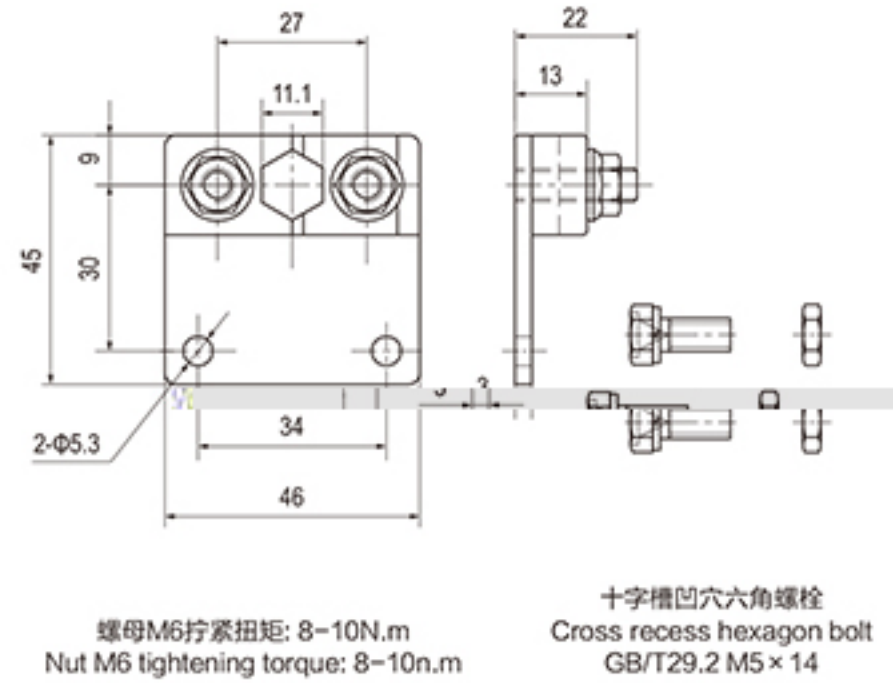

可选安装支架 (非电缆端)

Optional mounting bracket (not cable end)

